

Non Return Valve: Simple, easy and effective

A Non Return Valve is a simple and effective way to eliminate flood risk by backflow through drainage channels.

Particularly suitable for:

- Low – lying coastal, lake or valley areas, especially where rain water is channelled downstream to the main sewer, making it liable to flash-floods after heavy rainfalls.
- Under-dimensioned sewage networks with recent or scheduled new dwellings being connected on a previous main sewer operating at a high flowrate.
- Private discharge systems channelled to public sewers equipped with pumping stations.
- Commercial and industrial installations where non-pressure flow control is required (i.e. fish farming) or where PVC performance is required (salt water).
- Rodent ingress reduction.



Tel: 01379 644033
Fax: 01379 644073
enquiries@ifdp.co.uk
www.ifdp.co.uk

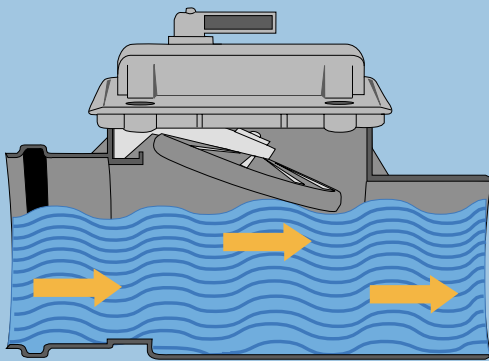
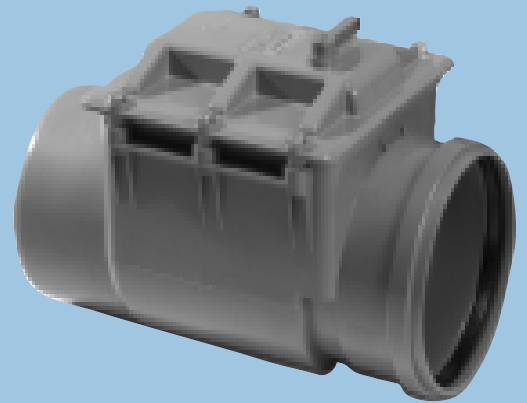

NORMAL WORKING SITUATION

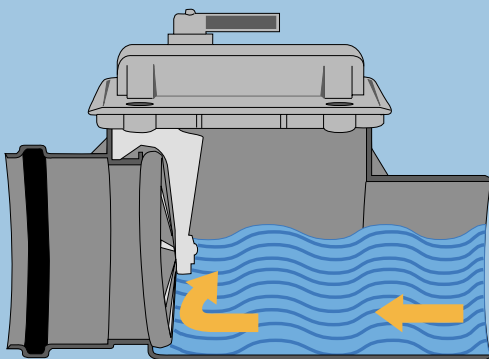

EFFECTIVE ANTI-FLOODING

100, 150 & 175 Diameter Non-return valve

DN	S	L1	L2	L3	L4	Price
110	4.0	61	61	307	230	
150	4.0	74	74	337	255	
175	4.5	100	86	451	300	

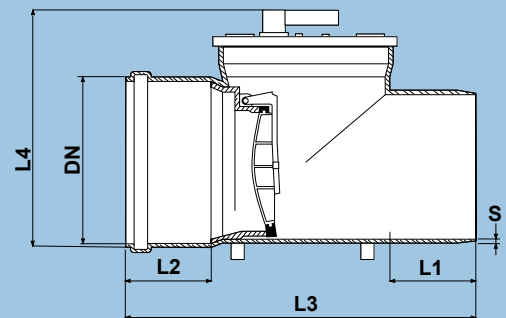

225, 300 & 375mm Diameter Non-return valve

DN	S	L1	L2	L3	L4	Price
225	6.2	130	102	520	374	
300	7.7	160	125	615	440	
375	9.8	205	145	780	460	

In accordance with Approved Document H1 of the Building Regulations and British Standards 8301: 1985, where a drain is liable to surcharge, measures should be taken to protect any building and ancillary area likely to be adversely affected. The measures necessary to protect a drainage system or building from surcharge should be as simple as possible and be so arranged as to have minimal effect on the drainage system.

Non-return valve is a simple, effective way to eliminate flood risk caused by back-flow through drainage channels.

The integral flap valve is the simplest design and when installed within the drain run the valve offers the most effective means of preventing flood damage.

Made from tough, anti-corrosion PVCu in 110mm and 160mm sizes.

SUITABLE FOR:

- Low lying coastal, lake or valley areas where a drainage system is laid to shallow depths or with flat gradients
- Where the building level is below the upper level of the main sewer
- Low lying coastal, lake or valley areas where a drainage system is laid to shallow depths or with flat gradients
- Where rainwater is channelled into the main sewer, making it liable to flooding during heavy rainfall
- Commercial and industrial applications where non-pressure flow control is required, for example, fish farming
- To reduce rodent ingress

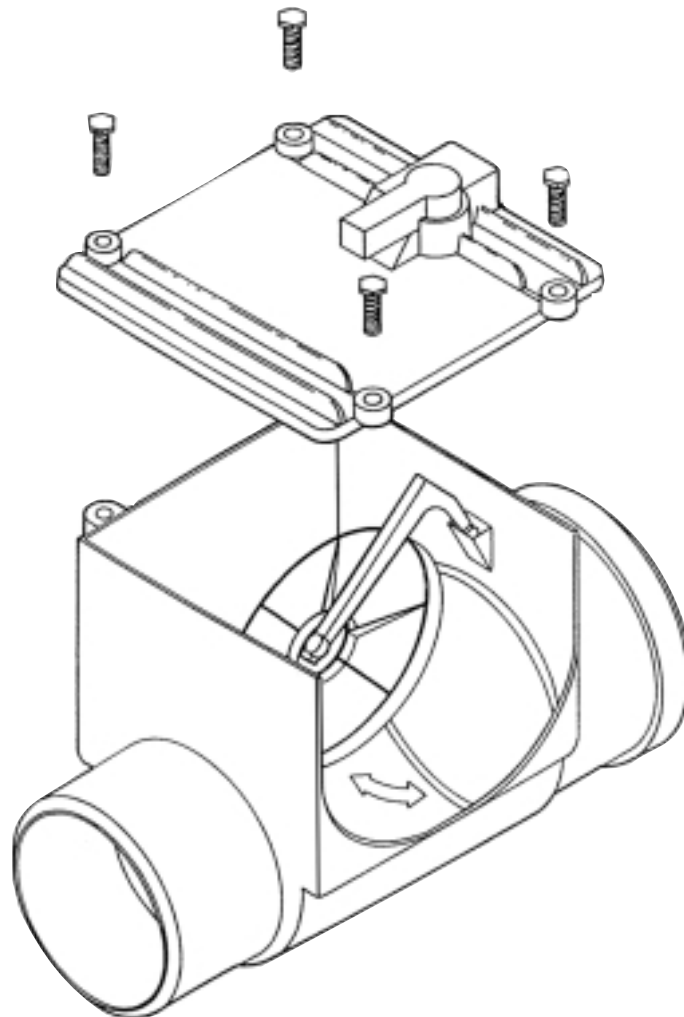

Note: recommended for installation within an access point for regular inspection maintenance and cleaning

7.13 NON-RETURN VALVE DS342/DS442 CONT-

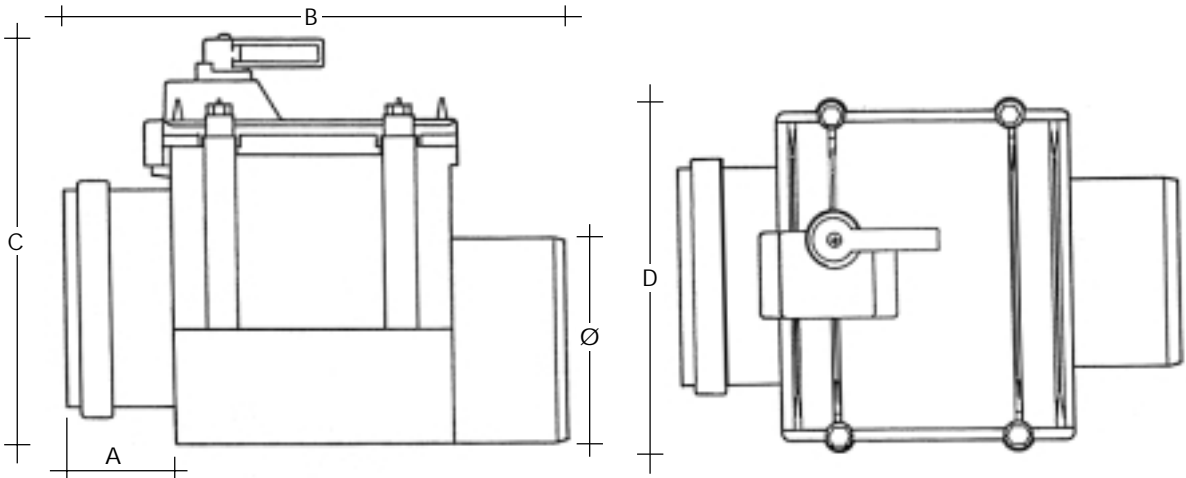

Dimensions (mm)	Ø	A	B	C	D
DS342	110	61	270	215	190
DS442	160	74	334	256	230

Note: The top of the valve is removable to aid cleaning and maintenance. The bolts use to secure the valve top can be removed using a 13mm socket or open-ended spanner.

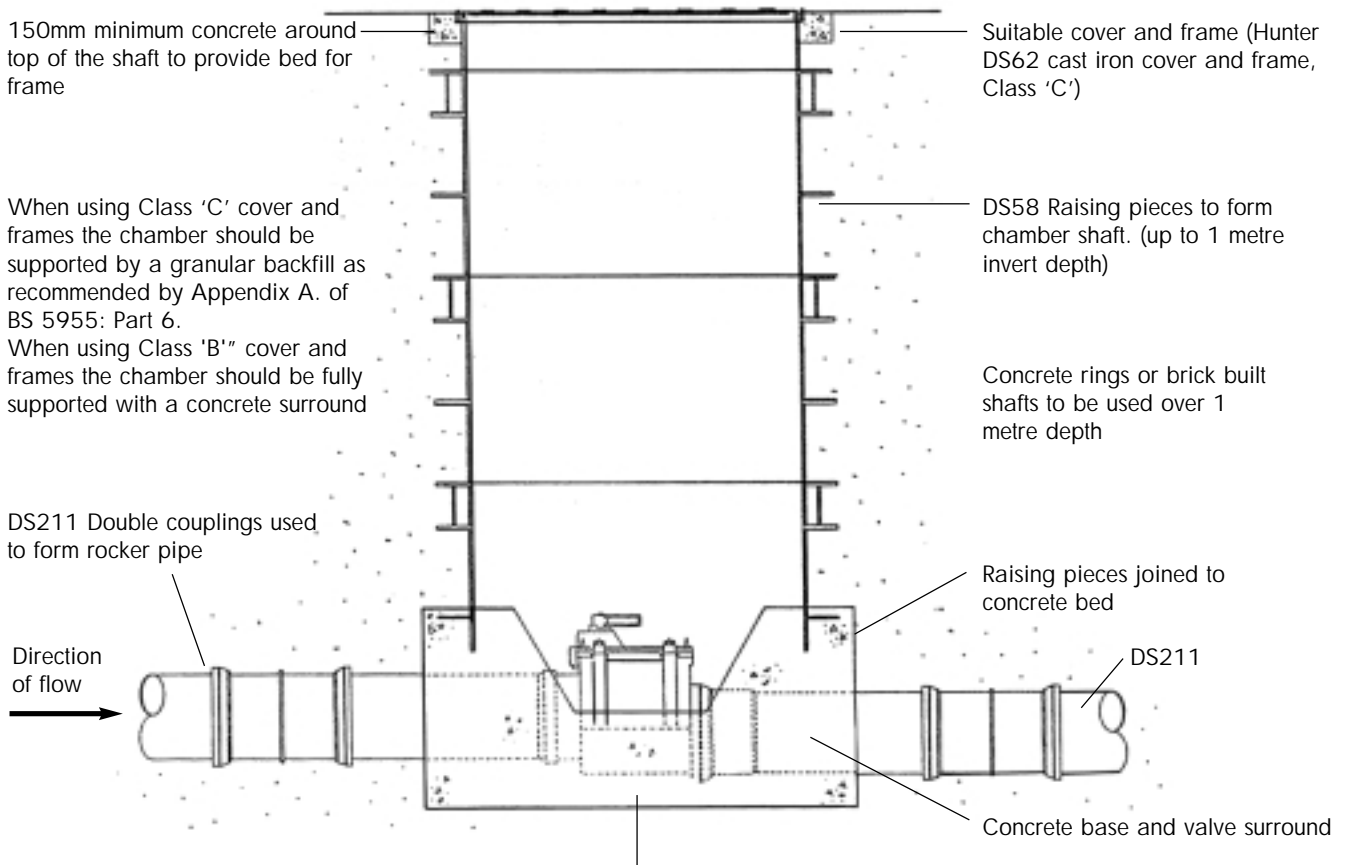

The valve should be installed within the drainage run and must be horizontal. This ensures that the flap opens under normal flow conditions and positively shuts off under surcharging conditions

7.14 NON-RETURN VALVE INSTALLATION NOTES

Install the non-return valve into its own chamber to make periodical inspection easier. Ensure that it is installed the right way round (socket upstream)

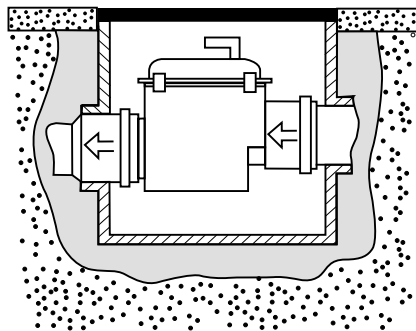

Install the valve longitudinally to the pipe, the maximum slope should not be more than two degrees (fall 1:27)

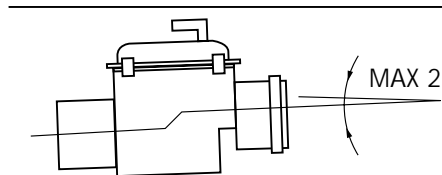

To ensure perfect operation of the valve it must be perpendicular (see drawing).

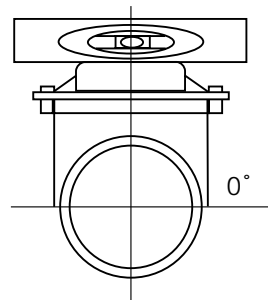

In order to periodically inspect the valve, rotate the handle toward the position 'closed'. In case of resistance to the rotation, remove the cover and clean the inside of the valve. Leave the handle in the open position under normal working conditions.

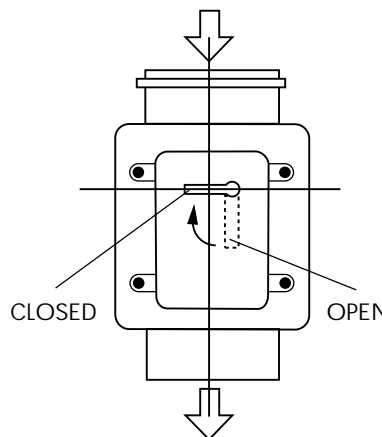

If the valve is positioned downstream of the soil pipe, the valve must be inspected frequently. Gradually tighten the bolts in the order shown 1 - 2 - 3 - 4.

